

Item description/product images

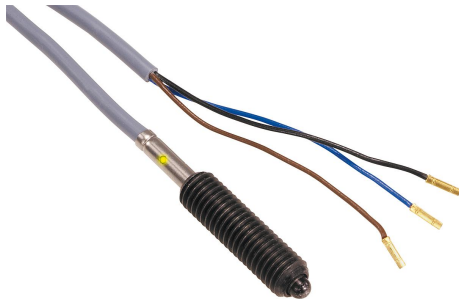

for electrics

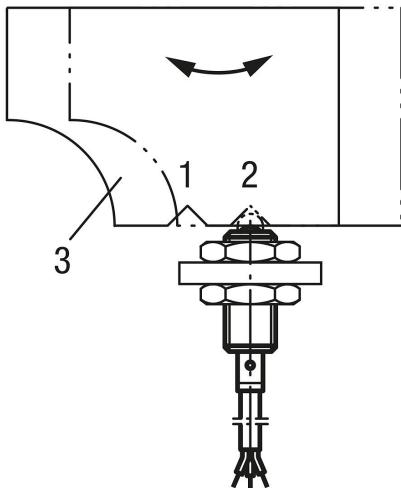

Description

Product description:

In addition to their mechanical function as an indexing and positioning element, spring plungers with status sensor are used to detect whether a component is in the desired position or not.

The sensor recognises whether the thrust pin is retracted or extended and enables this status information to be electronically processed.

Material:

Sleeve, thrust pin and spring, steel.

Status sensor stainless steel.

Version:

Black oxidised.

Thrust pin hardened.

Note:

The status sensor activates at a travel of H.

Technical data:

Inductive sensor:

Output relay: PNP normally open (NO) or normally closed (NC)

Operating voltage: 10 – 30 V DC

Operating current: <200 mA

Switch gap: 0.8 mm

Switching frequency: 2000 Hz

Short-circuit proof: yes

Reverse polarity protected: yes

IP rating: IP 67

Connection type: 2 m PVC cable

Approval: CE

Application:

Spring plungers with status sensor enable status-dependent process control. It can be ensured that a workpiece or moving component is in the desired location.

Temperature range:

Temperature range: -25 °C to +70 °C

Safety:

spring plunger with status sensor are not suitable for safeguarding persons.

Drawing reference:

4) LED-indicator

BN = brown

BK = black

BU = blue

Example of position feedback:

Pos. 1: slide engaged

Pos. 2: slide disengaged

3) Slide

Drawings

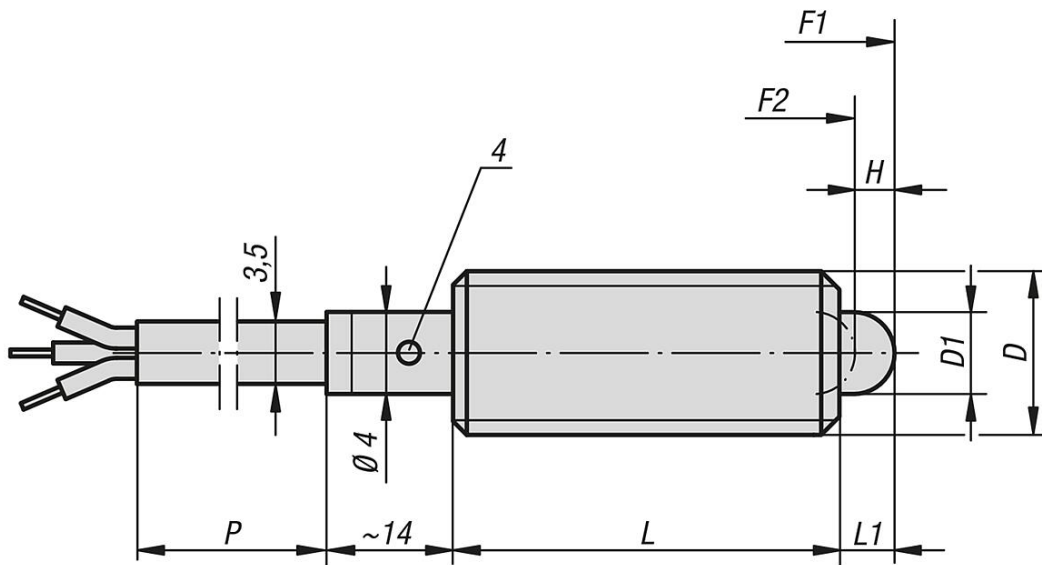

Overview of items

Order No.	Version 2	D	D1	H	L	L1	Switching contact from stroke H1	Spring force initial pressure F1 approx. N	Spring force final pressure F2 approx. N
03020-5061	normally closed	M6	2,7	2	27	3	1,2 - 1,6	7	20
03020-5081	normally closed	M8	4	2	29	3	1,2 - 1,8	15	30
03020-5101	normally closed	M10	4,5	3	36	4	2,2 - 2,8	26	44
03020-5062	normally open	M6	2,7	2	27	3	1,2 - 1,6	7	20
03020-5082	normally open	M8	4	2	29	3	1,2 - 1,8	15	30
03020-5102	normally open	M10	4,5	3	36	4	2,2 - 2,8	26	44