

Item description/product images

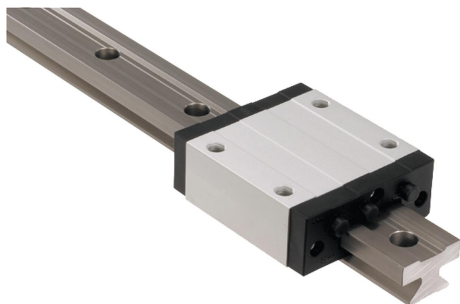

Description

Material:

Extruded section, aluminium EN AW-6060.

Version:

Hard anodised aluminium, 50 µm. Hardness 500 HV.

Note:

The aluminium guide rail has good thermal conductivity and importantly heats only at continuously very high speeds.

** lengths L2 = 20 mm

* and L = 500 mm included

L2 and L only available in full mm.

Drawings

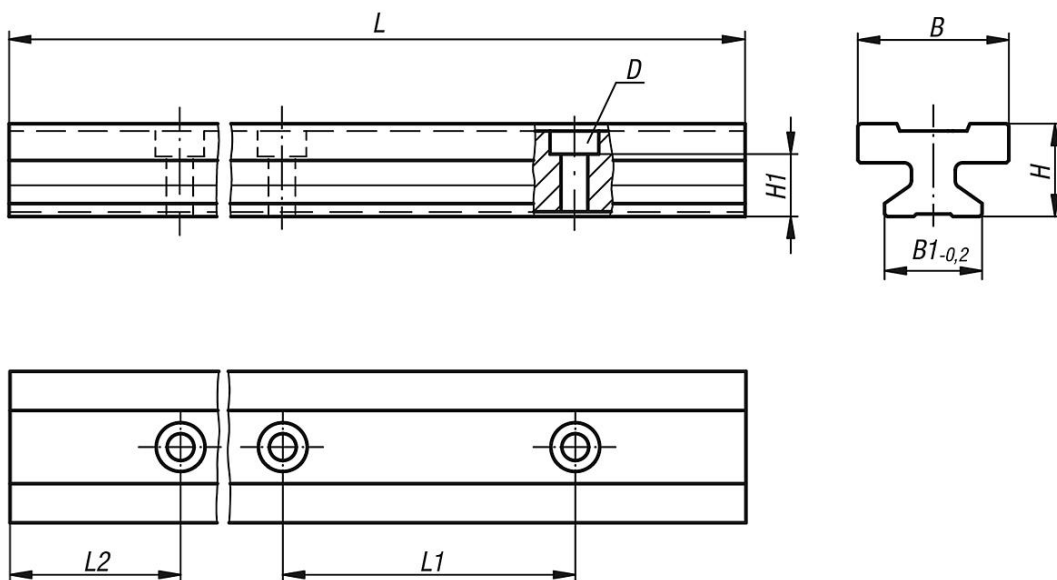

Overview of items

Order No.	Size	L max.	L2	B	B1	D for screw DIN 912	H	H1	L1
21200-1530X3960	15	3960	30	22	15	M4	15,5	10	60
21200-2030X3960	20	3960	30	31	20	M5	19	12,3	60
21200-2530X3960	25	3960	30	34	23	M6	21,5	13,8	60
21200-3020X3960	30	3960	20	40	28	M8	26	15,8	80

Order No.	Version 1	Size	L max.	L L2	L2 min.	L2 max.	B	B1	D for screw DIN 912	H	H1	L1
21200-15**X*	L2 and L customer specific	15	3960	* **	20	49	22	15	M4	15,5	10	60
21200-20**X*	L2 and L customer specific	20	3960	* **	20	49	31	20	M5	19	12,3	60
21200-25**X*	L2 and L customer specific	25	3960	* **	20	49	34	23	M6	21,5	13,8	60
21200-30**X*	L2 and L customer specific	30	3960	* **	20	49	40	28	M8	26	15,8	80

