

Item description/product images



Description

Material:

High-strength aluminium alloy

Version:

Natural tone anodised

Note:

Collets for clamping internal contours.

The contour of the workpiece to be held is inserted into the collet. Free-form and asymmetrical contours can be held.

The collet mechanism enables a secure clamping of the workpiece.

Clamping travel per collet segment (8x) max. 0.15 mm.

Workpiece repeat accuracy: ± 0.03 .

Collet repeat accuracy: ± 0.02 .

The traction cone 03169 is required when using the collet for internal clamping.

Matching adaptor 03167.

Drawings

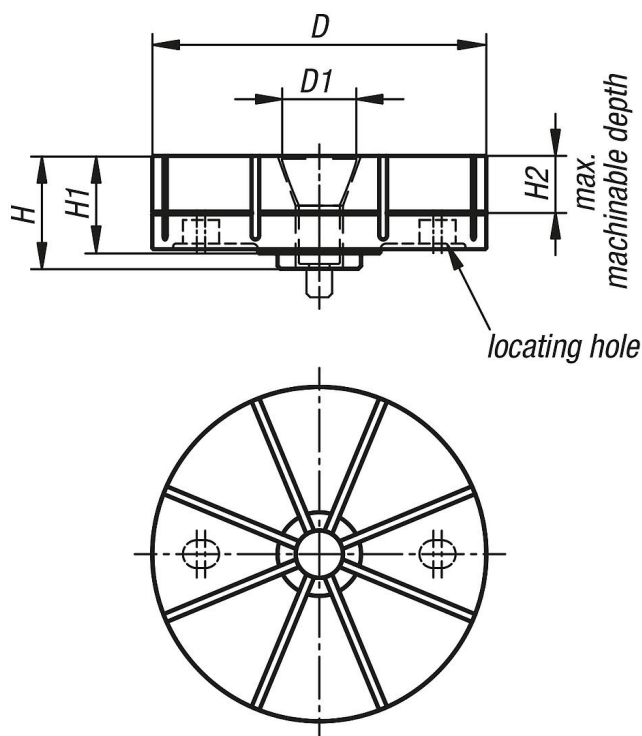

Drawings

1. Mounting collet:

- Insert an O-ring into the groove on the top face of the clamp base.
- Set a collet on the base making sure the locating pins fit into the locating holes on the underside of the collet.
- Secure the collet using a tapered screw.

Note:

Before mounting the collet, ensure the cam cylinder is fully loosened by turning the tightening screw counterclockwise until it stops.

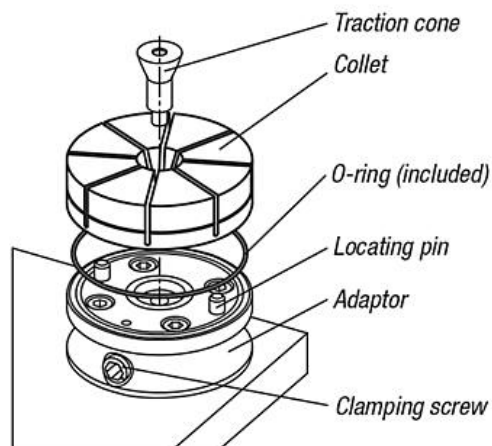

2. Machining collet:

2.1

Fully loosen the cam cylinder and measure the OD of the collet. Tighten the cam cylinder until the collet OD has expanded by 0.15 mm.

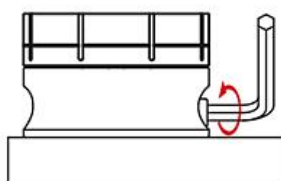

2.2

Machine the contour of the part that is to be held into the collet.

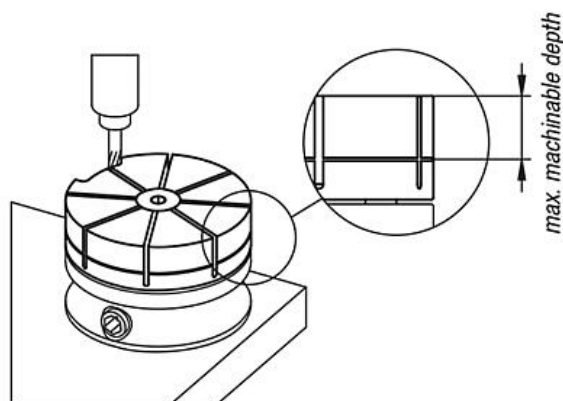

3. Mounting workpiece:

- Loosen the cam cylinder and remove the clamp ring.
- Place the workpiece in the contour and re-tighten the cam cylinder.

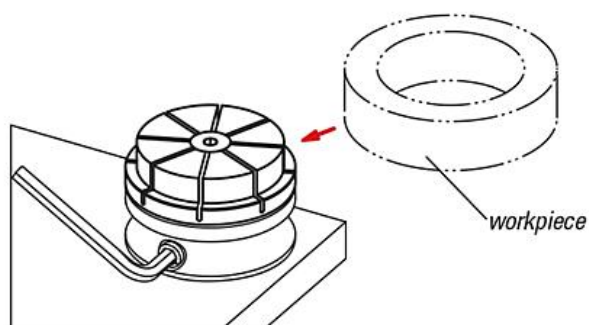

Performance curve

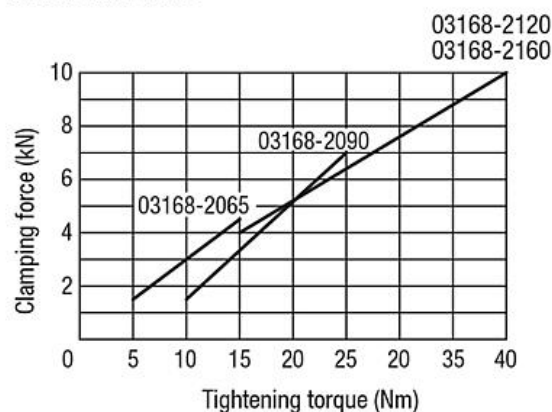

To avoid damaging the collet do not tighten the clamp without a workpiece or clamp ring. Observe the maximum tightening torque in the table.

Overview of items

Order No.	D	D1	H	H1	H2
03168-2065	65	22,5	28,5	25	10
03168-2090	90	27	34,5	30	15
03168-2120	120	29	40,5	35	20
03168-2160	160	33	46,5	40	25