

Item description/product images



Description

Material:

Steel.

Version:

Black oxidised.

Note:

The pivoting systems are adapted to measuring fixtures 33140.
Measuring arms see 33150.

Assembly:

- Place the conical clamping ring on the guide column and clamp in the desired position.
- Fix the conical centring ring to the pivoting sleeve and insert it such that the conical centring ring lies on top of the conical clamping ring.
- Fix the measuring arm onto the pivoting sleeve.
- Fix the second conical centring ring onto the pivoting sleeve.
- Insert the conical ring and pressure spring.
- Mount the pressure spring on the block with the clamping ring to prevent axial play.
- Lubricate all moving parts.

Drawings

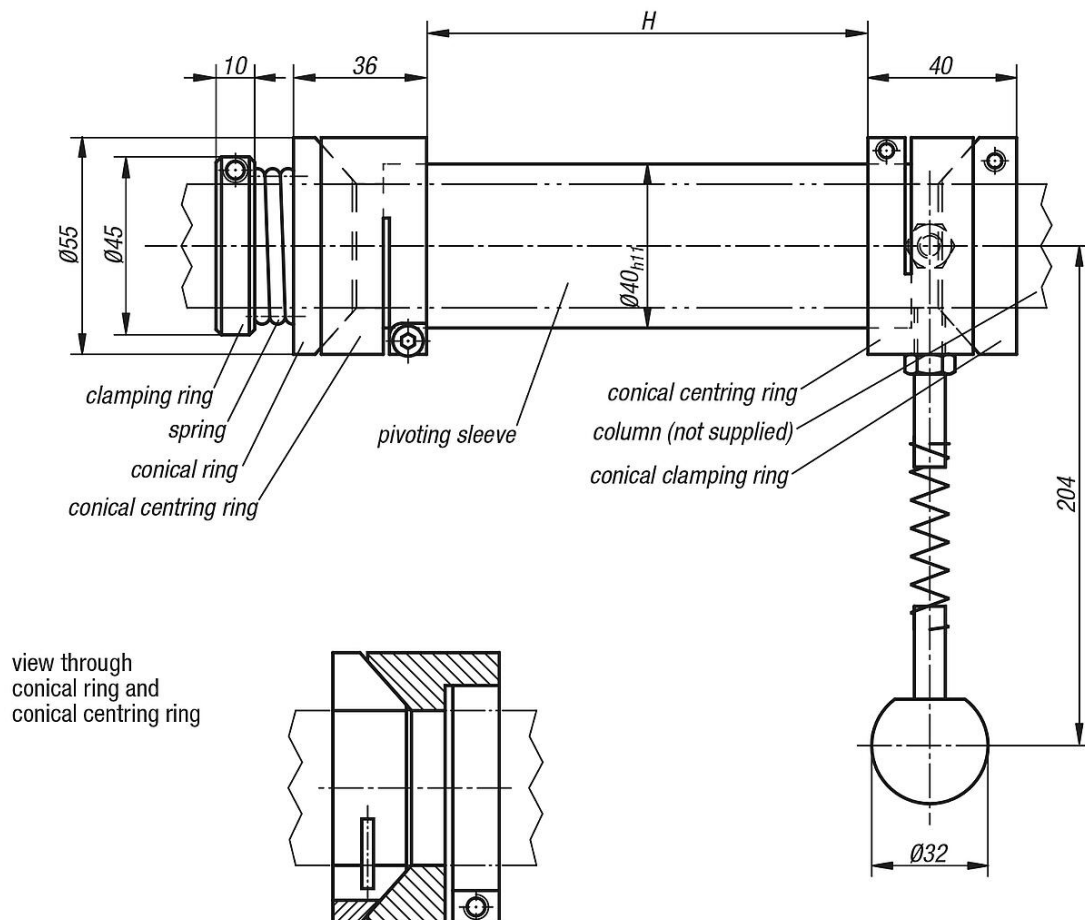

Drawings

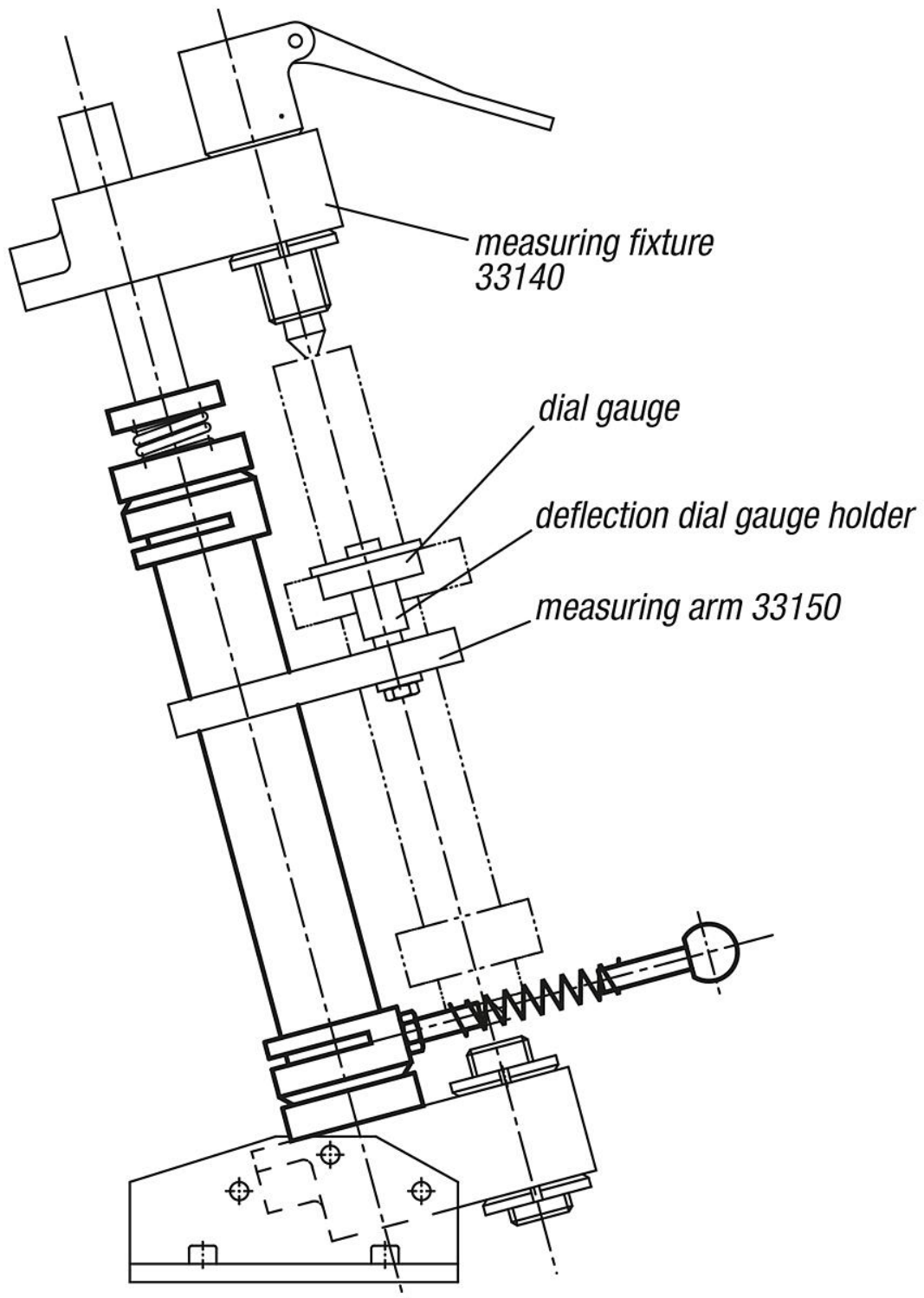

Overview of items

Order No.	H
33115-200	200
33115-276	276
33115-426	426
33115-536	536

