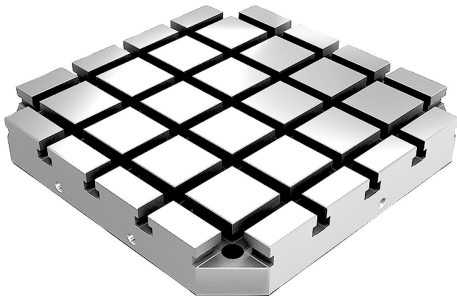

## Item description/product images

**Description****Material:**

GJL 300.

**Version:**

Support and mounting surfaces ground

**Note:**

Subplates with T-slots are used for constructing modular fixtures. These subplates are positioned and fastened directly on machine tables.

The precise longitudinal and transverse slot spacing ensures very high repeat clamping accuracy. The subplates conform to machine tables for machine tools acc. to DIN 55201 and JIS 6337-1980.

Please order locating pins for positioning subplates on machine tables acc. to DIN 55201 separately. Ring bolts with T-nuts for hoisting are supplied.

Other dimensions available on request.

**Drawing reference:**

1) hole for DIN 912 cap screw (D3/D4)

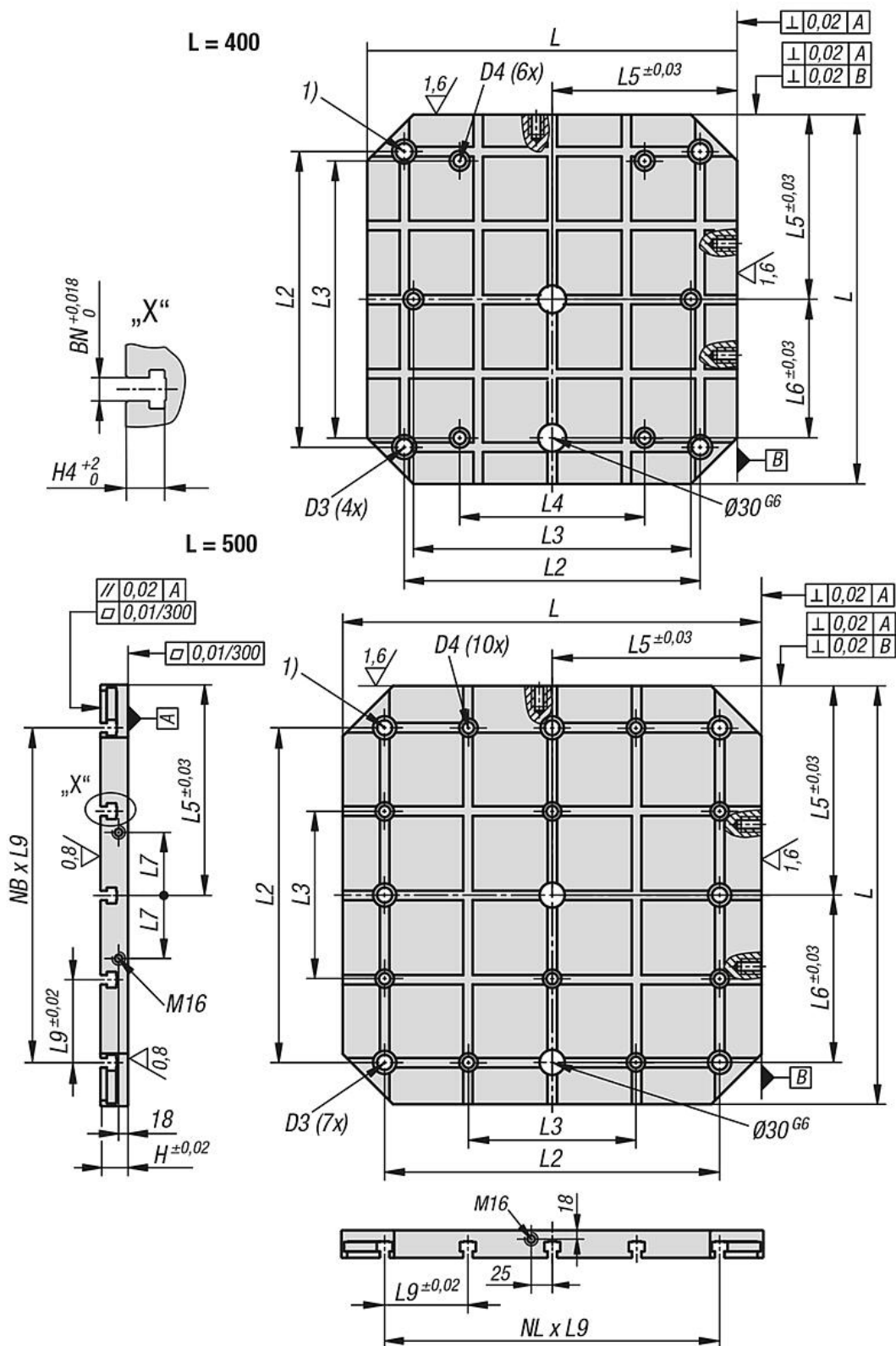

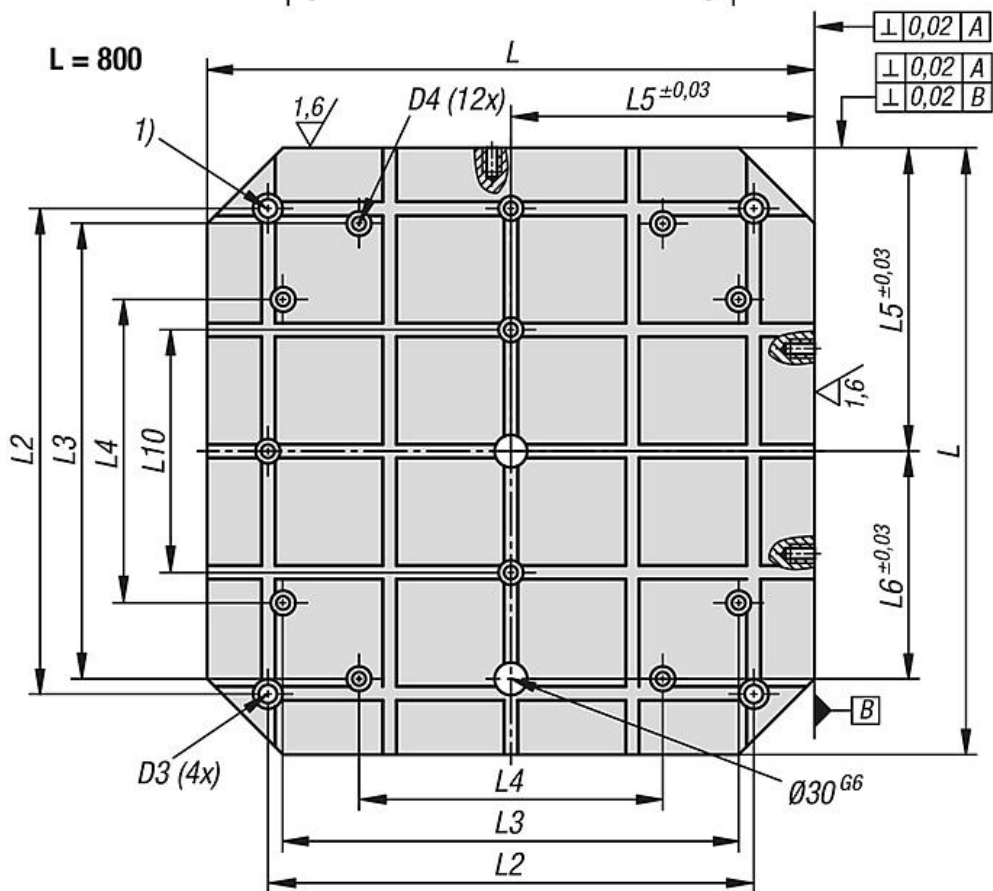
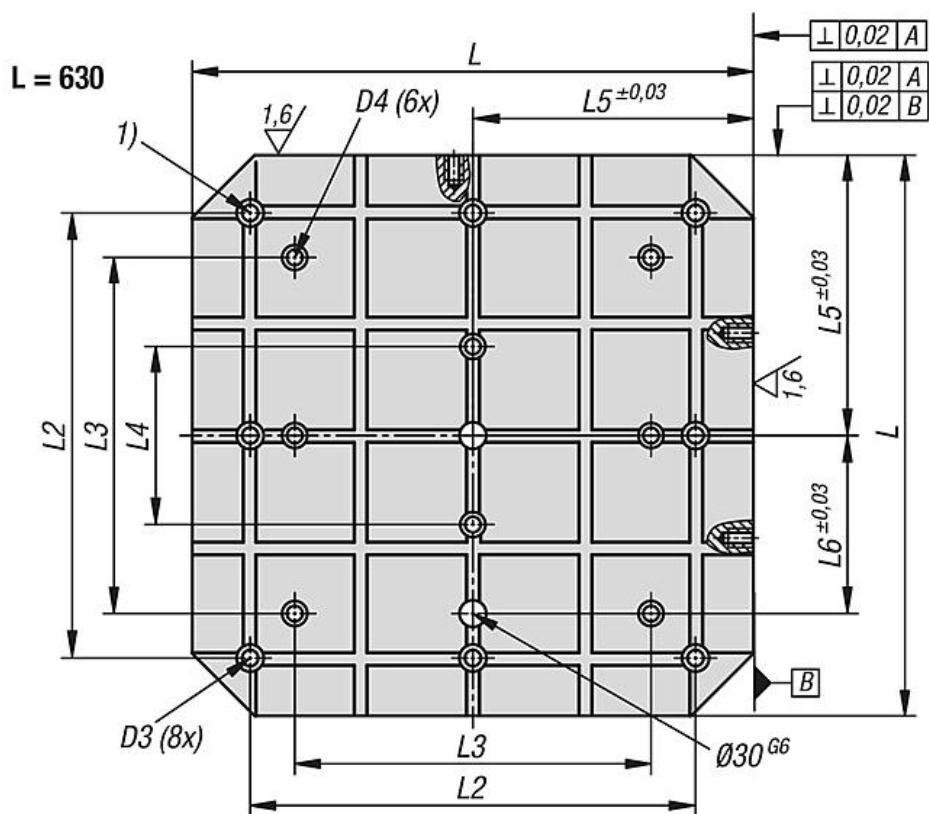

## Overview of items

Order No.	L	H	H4	D3	D4	L2	L3	L4	L5	L6	L7	L9	L10	BN=Slot width	NL=No. lengthwise	NB= No. across
01148-3144040	400	60	23	M16	M12	320	300	200	200	150	55	80	-	14	4	4
01148-3145050	500	60	23	M16	M12	400	200	-	250	200	75	100	-	14	4	4
01148-3146363	630	60	23	M16	M16	500	400	200	315	200	100	125	-	14	4	4
01148-3148080	800	60	23	M16	M16	640	600	400	400	300	135	160	320	14	4	4
01148-3184040	400	75	30	M16	M12	320	300	200	200	150	55	80	-	18	4	4
01148-3185050	500	75	30	M16	M12	400	200	-	250	200	75	100	-	18	4	4
01148-3186363	630	75	30	M16	M16	500	400	200	315	200	100	125	-	18	4	4
01148-3188080	800	75	30	M16	M16	640	600	400	400	300	135	160	320	18	4	4